

Trailer Catalog



Secure and Trusted

Quality Built Storage Equipment



Dakota Plains Fabrication, LLC is an innovative designer of storage products for the transportation and service industries manufacturing steel, stainless steel, and aluminum products.

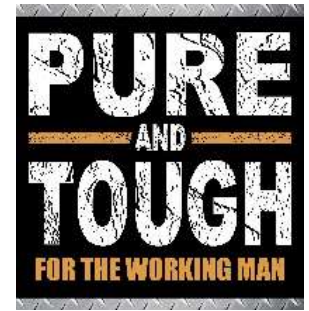

Dakota Plains Fabrication, LLC.

Dakota Plains Fabrication is your *One-Stop* source for industrial commercial equipment and has the most extensive range of storage products in the United States. With such a diverse range of products, outstanding designs, and engineering staff, Dakota Plains Fabrication can design and manufacture storage products for almost any requirement.

While the primary focus of products is for the work truck industry, Dakota Plains Fabrication also designs and manufactures many specialty and customized products. Call us with your idea and we will help you design a solution. We use 3D CAD software to design all the products we manufacture.

Introduction:

The purpose of this manual is to familiarize you with our company and our products. You will be able to use this manual to help you select the right product for the right job.

Our Mission:

To Be The Best Box Manufacturing Company In The Industry Today, Not The Biggest.

To furnish quality equipment, to those who will benefit from it at a competitive price. To provide follow-up service better than any other supplier. To be so good at what we do that you will never have a need to look elsewhere.

Index Page

No.	Model	Contents	Page	No.	Model	Contents	Page
Boxes for the Sportsman							
1.	TCT61-5	Traffic Control	3	2.	TCT61-6	Traffic Control	4
Mounting Brackets and Misc. Items							
3.	Specs	Specification	5	4.	DPF	Special Notice & Company Info	5

For Installation Guidelines and recommendation, visit our web page at: www.dp-fab.com and download our installation manual.

TCT61-5000 – Traffic Control Trailer.

Trailers are heavy duty and offer a great way to control traffic and store signs and other tools and many on the road. Trailers are available in different sizes and can be ordered custom size. Designed for Work Zone Safety. All Dakota Plains Fabrication trailers are designed and built to a quality you respect.

Description

- An Engineered Steel and Aluminum Construction
- HD Steel Powder Coated Frame
- Arrow Board Sign 48”x 96” - 25 LEDs 32 per lamp
- Smart Flash II Controller – Fuse Block Wiring
- Trailer Wiring - Grounded - Fuse Block
- HD Arrow Board Hydraulic Lift for Raising Board
- Solar Pannel Prostar III Controller with 160W-24V Solar Panel
- ATB HD A-Frame Box - Four 6-Volt Deep Cycle Batteries
- Aluminum Sign Box - Fully Enclosed - SS Hardware and Hinge
- Stainless Steel Bar Latch Lock with Commercial Weather Seal
- 7K 8-Lug Torflex Axles - Steel Wheels - Spair Tire and Holder
- Storage Compartment for Signs and Stands
- Adjustable Tow Hitch with 3” Eye
- Wheel Chocks Wedges - Barricade Holders Posts
- Four Traffic Cone Holders Posts - Wheel Chock Set
- Four SS Sand Bag Pockets

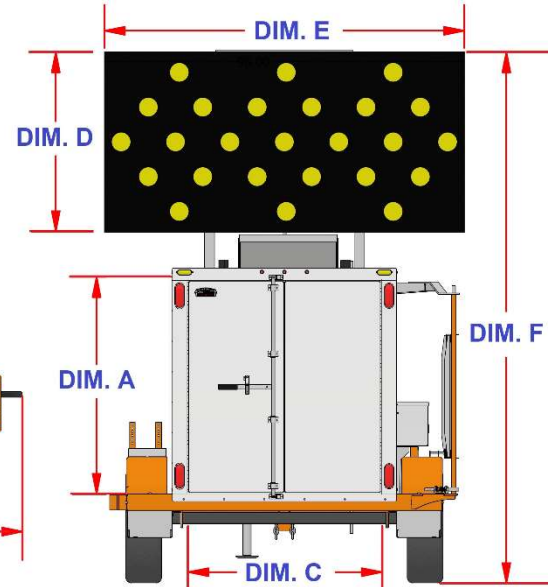
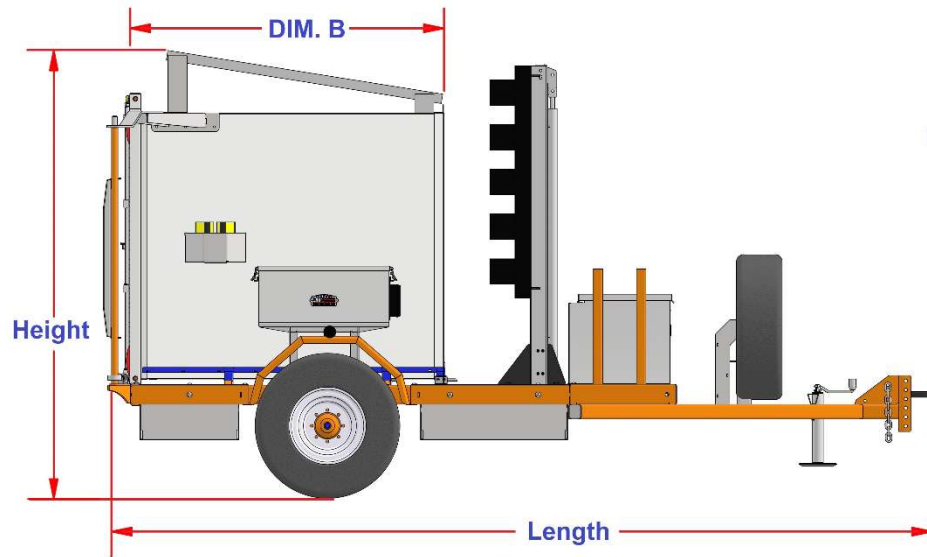
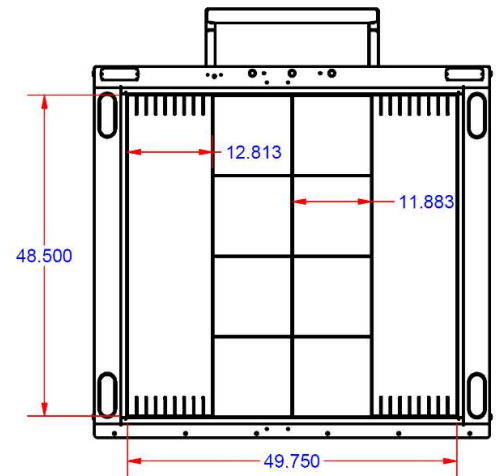

Note: Measurements and weight may vary and will change with trailer design and added options.

No.	Model Number	Material (gauge)	Height (in.)	Length (in.)	Width (in.)	Dim. A	Dim. B	Dim. C	Dim. D	Dim. E	Axles (lbs.)	Wheel Hub Face	Tire (size)	Weight (lb.)
1.	TCT61-5011-LXO	1/8"-3/16	92	170	96	49	54	50	48	96	7K	74.75	235/80	2800

Note: Trailers are available in different configuration and custom sizes; call the factory for different sizes and options.

TCT61-6000 – Traffic Control Trailer.

Trailers are heavy duty and offer a great way to control traffic and store signs and other tools and many on the road. Trailers are available in different sizes and can be ordered custom size. Designed for Work Zone Safety. All Dakota Plains Fabrication trailers are designed and built to a quality you respect.

Description

- An Engineered Steel and Aluminum Construction
- HD Steel Powder Coated Frame
- Arrow Board Sign 48”x 96” - 25 LEDs 32 per lamp
- Smart Flash II Controller – Fuse Block Wiring
- Trailer Wiring - Grounded - Fuse Block
- HD Arrow Board Hydraulic Lift for Raising Board
- Solar Pannel Prostar III Controller with 160W-24V Solar Panel
- ATB HD A-Frame Box - Four 6-Volt Deep Cycle Batteries
- Aluminum Sign Box - Fully Enclosed - SS Hardware and Hinge
- Stainless Steel Bar Latch Lock with Commercial Weather Seal
- 7K 8-Lug Torflex Axles - Steel Wheels - Spair Tire and Holder
- Storage Compartment for Signs and Stands
- Adjustable Tow Hitch with 3” Eye
- Wheel Chocks Wedges - Barricade Holders Posts
- Four Traffic Cone Holders Posts - Wheel Chock Set
- Four SS Sand Bag Pockets

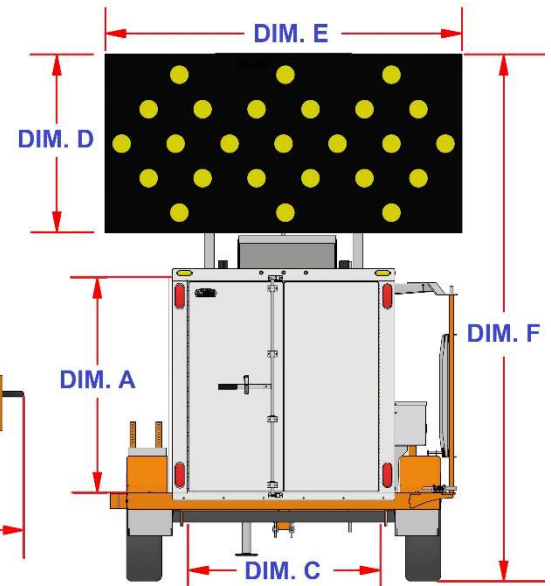
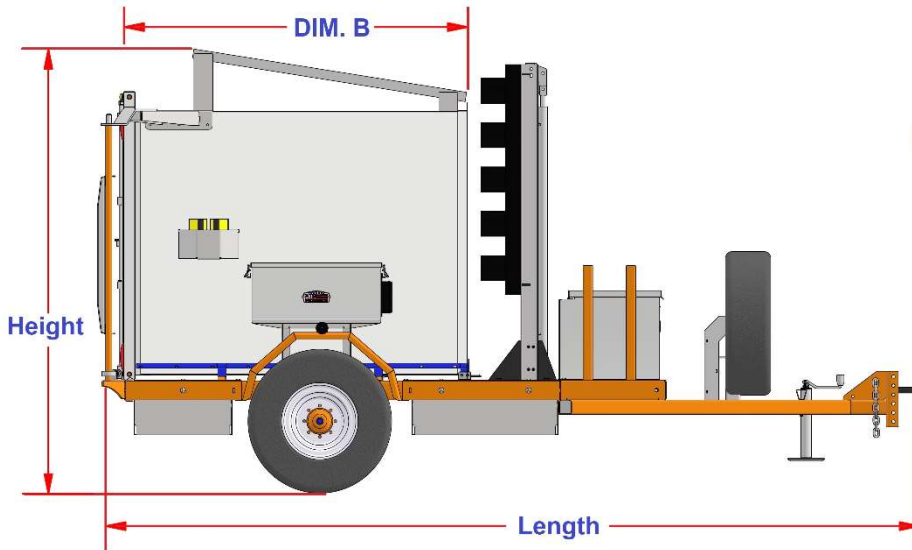
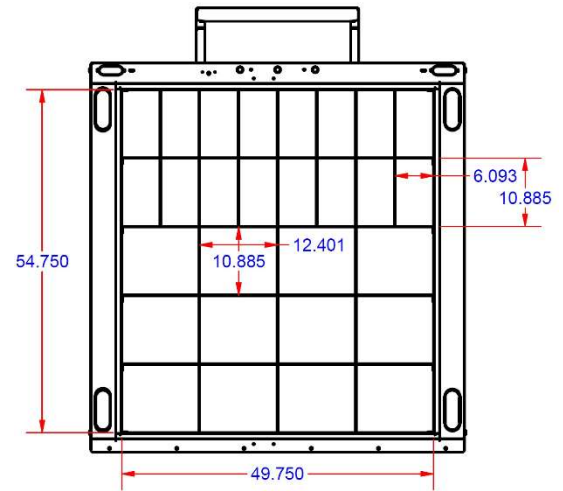

Note: Measurements and weight may vary and will change with trailer design and added options.

No.	Model Number	Material (gauge)	Height (in.)	Length (in.)	Width (in.)	Dim. A	Dim. B	Dim. C	Dim. D	Dim. E	Axles (lbs.)	Wheel Hub Face	Tire (size)	Weight (lb.)
1.	TCT61-6011-LXO	1/8"-3/16	92	170	96	55	72	50	48	96	7K	74.75	235/80	2950

Note: Trailers are available in different configuration and custom sizes; call the factory for different sizes and options.



Specification:

Decoding Part Number		T CT 6 1 - 50 1 1 - L X O	
Decoding Type Number: _____	_____	_____	Color: _____
T=Trailer	_____	_____	Option: _____
Model: _____	_____	_____	Size: _____
Duty: _____	_____	_____	Controller: _____
3=Medium Duty --- (16g Steel / 16g or .63Alum)	_____	_____	Panel: _____
4=Heavy Duty --- (14g Steel / 14g or .100 Alum)	_____	_____	Series: _____
5=Super Heavy Duty (12g Steel / 10g or .125 Alum)	_____	_____	
6=Mega Heavy Duty (10g Steel / 07g or .190 Alum)	_____	_____	
Style: _____	_____	_____	

Serial Number:

Decoding Serial Number		T 26 1 - 1 - 01 - 0	
Decoding Build Number: _____	_____	_____	MO Manufacture Order: _____
T=Trailer	_____	_____	Units Build Number: _____
Year: _____	_____	_____	Version: _____
Month: _____	_____	_____	

Special Notice: This manual contains drawings and written material, which are for the sole purpose of mounting and providing guidelines for installing our boxes and/or equipment in various configurations. Keep in mind that these are only intended as guidelines and not to be construed as construction drawings or specifications.

Dakota Plains Fabrication, LLC shall not be responsible in any way for anything other than the providing of equipment and materials ordered. Guidelines shown in this manual may not meet or be in accordance with local, state, or federal regulations in effect at time of installation. **Dakota Plains Fabrication, LLC has the right to make changes in design at any time without notice.**

Office Hours: Monday through Friday - 8:00am to 12:00am and 1:00pm to 5:00pm

Dakota Plains Fabrication, LLC. 15750 - 6th Street SE, Blanchard, ND 58009

Phone: (888) 996-0376 **Email:** sales@dp-fab.com

For installation guidelines, visit our web page at: www.dp-fab.com and download our installation manual.

DAKOTA PLAINS FABRICATION, LLC. - LIMITED WARRANTY

This LIMITED WARRANTY is made by Dakota Plains Fabrication, LLC, 15750 - 6th Street SE, Blanchard, North Dakota 58009 to the original retail purchaser of American Truckboxes, LLC products. If you have any questions or need assistance regarding this warranty and the warranty of your product, please call our customer service department at: (888) 996-0376, between the hours 8:00AM to 5:00PM CST. This warranty applies to all product purchased on or after January 1, 2026.

DAKOTA PLAINS FABRICATION, LLC WARRANTS THAT THIS PRODUCT WILL BE FREE FROM DEFECTS IN MATERIAL AND WORKMANSHIP FOR A PERIOD OF TWELVE-FOUR (24) MONTHS ON STANDARD TRAILERS, TWELVE (12) MONTHS ON CUSTOM TRAILERS (MODIFIED OR SPECIAL DESIGN TO CUSTOMER SPECIFICATIONS) AND TWELVE (12) MONTHS ON CUSTOM PRODUCTS AND AUXILIARY TANKS, FROM DATE OF PURCHASE BY THE ORIGINAL RETAIL PURCHASER ONLY. THIS WARRANTY TERMINATES IF THE ORIGINAL PURCHASER TRANSFERS THE DAKOTA PLAINS FABRICATION, LLC PRODUCT TO ANY OTHER PERSON.

If purchaser discovers that the product fails to fulfill the warranty before the warranty period, original purchaser must promptly contact Dakota Plains Fabrication, LLC in writing of the nonconformity, to make arrangement for an inspection of this product. A copy of the original sales receipt must be supplied to the manufacturer at the time a warranty claim is made. If Dakota Plains Fabrication, LLC determines a defect exists, Dakota Plains Fabrication, LLC shall, at its option and expense, repair or replace any defective parts. All warranty repairs shall be made by an authorized Dakota Plains Fabrication, LLC product dealer or Dakota Plains Fabrication, LLC approved service man. Any part or parts of the goods not manufactured by Dakota Plains Fabrication, LLC are not warranted for any purpose.

This warranty shall not apply or expressly exclude, if the Dakota Plains Fabrication, LLC product has been subject to an accident, normal wear and tear, cosmetic rust, scratches, unlawful vehicle operation, act of God, improper maintenance, misuse or alteration made by anyone other than Dakota Plains Fabrication, LLC or a product dealer of Dakota Plains Fabrication, LLC approved service personal or company. Defects resulting from conditions beyond the manufacturer control, but not limited to, overloading, misuse or failure to assemble or mount the product according to the manufacturer's installation guide line, written instructions or damage to the contents of the box or vehicle.

Purchaser must deliver written notice of any claimed defect or failure covered by this Limited Warranty within thirty (30) days after discovery. Such notice must specify the date of purchase as well as the nature of the defect or failure.

THE WARRANTY PRINTED ABOVE IS THE ONLY WARRANTY TO THIS PURCHASE. ALL OTHER WARRANTIES, EXPRESS OR IMPLIED, INCLUDING BUT NOT LIMITED TO THE IMPLIED WARRANTIES OF MERCHANTABILITY AND FITNESS FOR A PARTICULAR PURPOSE ARE HEREBY DISCLAIMED.

American Made Products

Advantages & Benefits

Why Choose Dakota Plains Fabrication?

Dakota Plains Fabrication is a USA Manufacturer that specialize in manufacturing heavy duty truck storage equipment or trailers for the truck and trailer industry for over 25 Years.

We use only the highest quality material, parts and heavy gauge steel or aluminum. **All our steel boxes are primed and top coated with zinc epoxy primer and a super durable baked topcoat powder coat finish.**

Our primary focus is using heavy-duty stainless-steel hinges, lid supports, heavy duty dual gas springs, easy workable dividers, shelves, trays, automotive weather stripping, superior anti-theft designs and lock systems designed to withstand severe weather conditions and much, much more.

Are Dakota Plains Fabrication Products the Right Fit For Me?

Dakota Plains Fabrication products are available in many sizes, appropriate for any size truck or vehicle. They may be installed on either new or pre-owned trucks. We know your truck, tools and equipment is everything to you, so we design our products based on what we hear back from you. Your knowledgeable Dakota Plains Fabrication dealer or representative can help select, the best box that is best for you.

Do I get a warranty with this product?

All products come with a limited warranty for defects in material and workmanship (see www.dp-fab.com for full warranty detail). Dakota Plains fabrication, LLC. is dedicated to continuous product research, development and reserves the right to change design and specifications without notice.

All products come with a limited warranty for defects in material and workmanship (see www.dp-fab.com for full warranty detail). Dakota Plains Fabrication, LLC. is dedicated to continuous product research, development and reserves the right to change design and specifications without notice.

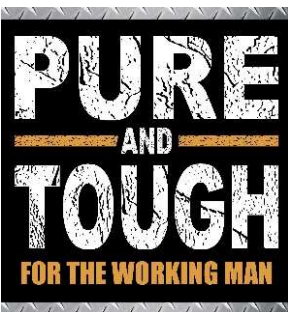

WWW.DP-FAB.COM